



Dear Land Speed Racer,

Thank you for requesting a 2016 FIM Packet. Enclosed you will find documents that will assist you in completing the FIM licensing and attempt application required for a world record attempt at the Bonneville Motorcycle Speed Trials at Bonneville.

There are a large number of items to complete, and the paperwork can be somewhat overwhelming so please contact us should you need assistance getting through the process.

PLEASE NOTE:

- FIM entry consists of 3 parts:
 - (a) Rider Licensing,
 - (b) World record attempt application,
 - (c) Bonneville Motorcycle Speed Trials entry.

- Paperwork is due to the FIM 30 days prior to the event. The AMA will need to forward your paperwork to the FIM. All this **MUST** be completed **before** the deadline. We have set deadlines for the paperwork to arrive at the AMA to ensure we have enough time to confirm it's complete and submit it to the FIM. If you do not meet the deadlines we cannot guarantee that your paperwork will be submitted in time (deadlines are listed on the checklist)

- The rider certification fee for a world record attempt is \$300* USD per **SUCCESSFUL** attempt. You are only charged for a **SUCCESSFUL** world record attempt after the fact. **Payment may be requested onsite prior to being processed for a record.** FIM ratification generally takes place at the FIM Congress Meetings in October of each year. The \$300* fee will be for the FIM ratification process as well as receiving a certificate for the Mile and Kilometer. The AMA will invoice you (rider) when the fee is required.
* Charges based on current Euro exchange rate

- Your AMA membership must be valid **THROUGH** the end of the year. You will be required to renew your membership if it expires before December 31st 2016. There is a place on the License application to do this.

- As part of your FIM License application you are required to pay a fee (payable to the AMA) that covers accident medical insurance for participating in the event. This is automatically included on your License application (\$150) and does not require you to complete anything further than the License application form. The coverage provided by the insurance is available by request.

- The FIM rules are available at www.fim.ch in the Library section. They can also be found through links on the Bonneville Speed Trials website.

- Each motorcycle will require a separate *World Record Attempt Application* (part b). This is also true if you compete in an additional class (i.e. with fairing (div b) and without fairings (div a)) with the same vehicle. Please include full Category/Group/Division/Type/Class/No. of Cylinders in the appropriate sections on the World Record Attempt Application.
- If you have one vehicle but more than one rider, BOTH riders must be licensed to be eligible for the world record attempt. You need also to submit a WR application for each rider, and an additional rider form for BMST entry.
- ***IMPORTANT*** if you do not hold an AMA Pro Racing License nor have you obtained and FIM license in the past, it will be necessary for you to include a racing resume and references on your racing experience, i.e. letter from race manager/track/news clippings of winnings, etc as your application is subject to approval.

FEES

Payable to AMA:	License Fee \$100 Insurance \$150 AMA Membership \$49 (if applicable)
Payable to FIM:	Certification fee \$300 USD for each attempt (will be billed by the AMA)
Payable to BMST:	Entry Fee \$775 (see details for included items on event website)

Included in this packet you should have the following documents:

- FIM Entry Checklist
- Rider Licensing (a)
 - 2016 FIM License Application
 - AMA 2016 Adult Annual Participant Release (If participant is a minor- please download from AMA's website)- **Must be printed in color**
 - FIM Medical History & Examination
 - FIM Anti-Doping Code (1 page)- Read the full code online.
- FIM World Record Attempt (b)
 - World record attempt application
 - FIM Classification flow chart & AMA to FIM conversion chart

If you have any question regarding the enclosed paperwork please contact the event :
Ph- (530) 263 7276 or email: entry@bonneville-speedtrials.com and we will be happy to answer your questions and guide you through the process.

Your documentation is to be submitted to the AMA, Attn: Jessica Robinson, 13515 Yarmouth Dr, Pickerington OH 43147 or emailed to jrobinson@ama-cycle.org

Sincerely,
Delvene Manning
Event Manager

Linnea Johnston
Registration



FIM ENTRY CHECKLIST.

In order to compete for a world record at the Bonneville Motorcycle Speed Trials, advanced preparation is required. This checklist is designed to assist in the process to ensure all the appropriate paperwork is submitted. **This checklist applies to USA residents only.**

FIM entries consist of 3 parts: (a) Rider Licensing, (b) World Record Attempt Application, (c) Bonneville Speed Trials entry. All 3 parts must be completed in full and submitted to the AMA & Bonneville Speed Trials by the stated deadlines.

PLEASE READ THE CHECKLIST- SOME PROCEDURES HAVE CHANGED FROM EARLIER YEARS

- READ the FIM rule book (<http://www.fim-live.com/en/sport/sport/world-records-attempts/>) or via www.bonnevillespeedtrials.com in the rules and records page. It is your responsibility to read and understand the rules.

- Complete FIM license application (a)
 - Complete *2016 FIM LICENSE APPLICATION* form
 - Sign and **notarize** the *AMA ANNUAL ADULT RELEASE....etc.*
 - Complete *MEDICAL HISTORY & EXAMINATION* forms- One page **MUST** be completed by your doctor. NB: Exercise EKG required for participants over 50 years old. Results are valid for 3 years see page 19 rule 09.2.1 Medical Code)
 - Read *FIM ANTI-DOPING CODE*. The document is available online (http://www.fim-live.com/fileadmin/user_upload/FIM_ANTI_DOPING_CODE_2016.pdf) Sign *APPENDIX 3- Consent Form* included in packet
 - Racing resume, reference or evidence of racing experience (if you never had an FIM application).
 - Make payment payable to AMA** (license fee \$100 + Insurance fee \$150 + AMA renewal if applicable).

- Complete *WORLD RECORD ATTEMPT APPLICATION* form (b)
 - Rider must sign the form- your license number will be added by the AMA.
 - Include with your application:
 - o Photos certifying the condition of the machine (2 photos with fairing and 2 without fairings), the effectiveness of the safety points (photos of each point). Digital format required (CD or email). Please use hi-res 500kb or larger to ensure that the bike can be seen.
 - o All machines must provide photos- even if it has participated before in the same configuration.

- Submit both (a) forms and (b) forms to the AMA **NO LATER than July 20th 2016**. If we do not receive it by July 20th we cannot guarantee that it will arrive at the FIM by their 30 day deadline. Mail to:
 - o AMA Attn: Jessica Robinson or email: jrobinson@ama-cycle.org
13515 Yarmouth Dr
Pickerington, OH 43147

- Complete Entry Form online. (<http://bonnevillespeedtrials.com> entry section)
 - Select event: FIM World Records Registration
 - Submit entry **NO LATER than July 11th 2016**. (Late fee applies after July 11th and FIM entry will not be guaranteed for late entries)

FOR OFFICE USE ONLY

FIM License # _____ Date Mailed: _____ Clerk/Coordinator: _____



2016 FIM LICENSE APPLICATION
(Fill out completely - Print or Type)



Name: _____
(First/Middle/Last)

AMA/ATVA Membership #: _____ Exp. Date: _____
(AMA membership must be current through year applying for)

Address: _____

City/State/Zip: _____

Home Phone: (_____) _____ Cell: (_____) _____ Work: (_____) _____

Fax: (_____) _____ Email: _____

Age: _____ Date of Birth (MM/DD/YY): _____

Place of Birth: (City/State/Country) _____

US Citizen: Yes ___ No ___ How long have you lived in the US _____

Nationality: _____

Next of Kin: _____

(Name/Relation/Phone)

License Category Applied For

Enduro	_____	Motocross	_____
Supercross	_____	Road Race	_____
Trials	_____	Speedway	_____
Other	_____		

Event Information

Date & Location of Event: _____ IMN # _____
(MM/DD/YY) / Country

Event Title: _____

Date of Departure _____

Total Fees Submitted

License Fee	\$	_____
Insurance \$125.....	\$	_____
AMA Membership \$49 (If Applicable)	\$	_____
Total Fees Submitted:.....	\$	_____

Applicant's Legal Signature: _____

Method of Payment

Check or Money Order # Enclosed (Payable to AMA): _____ Amount: \$ _____

Credit Card (√ one): _____ Visa _____ MasterCard _____ Discover _____ American Express

Card Number: _____ Exp. Date _____

Cardholder's Name: _____

Cardholder' Signature: _____

Return to: American Motorcyclist Association
AMA Racing
13515 Yarmouth Dr., Pickerington, OH 43147
Ph: 614-856-1910 ext. 1278; Fax: 614-856-1924

09.1 MEDICAL CERTIFICATE AND EXAMINATION

Every rider taking part in motorcycle competition events must be medically fit. For this reason a satisfactory medical history and examination are essential. The medical history and medical examination forms are contained in Appendices A and B. The medical certificate is valid for not more than one year. In the event of serious injury or illness occurring following the issue of a medical certificate, a further examination and medical certificate are necessary.

In addition to the medical examination, an applicant for any licence in Cross-Country Rallies (World Championship, FIM Prize, international events) must undergo and pass successfully an echocardiogram once in his lifetime prior to the issuing of the licence. An exercise tolerance electrocardiogram must be conducted and successfully passed with this echocardiogram and is then required every three years.

Regarding the duration of convalescence after injury please refer to Appendix L.

09.1.1 GUIDELINES FOR THE EXAMINING DOCTOR

(To be issued with the medical history [Appendix A], and medical examination [Appendix B] Forms).

The examination should be performed by a doctor familiar with the applicant's medical history. The examining doctor must be aware that the person to be examined is applying for a licence to participate in motorcycle events. The purpose of the examination is to determine whether the applicant is physically and mentally fit to control a motorcycle in order to ensure the safety of other riders, officials and spectators during an event, having regard to the type of event for which the rider is applying.

Certain disabilities exclude the granting of a licence.

LIMBS

The applicants should have sufficient function of their limbs to permit full control of their machine during events. In the case of loss or functional impairment of all or part of a limb or limbs the applicant may be referred for the opinion of the medical commission of his FMN.

EYESIGHT

The minimum corrected visual acuity must be 6/6 [10/10] with both eyes open together. The minimum binocular field should measure 160 degrees (120 degrees for monocular vision with 60 degrees each side), 30 degrees vertical.

Spectacles, if required, should be fitted with shatterproof lenses and contact lenses, if worn, should be of the “soft” variety.

A person who suddenly loses sight in one eye will not be allowed to hold a licence until a minimum of three years have elapsed, except for Trial in which the period of ineligibility is one year, with vision (corrected if necessary) not less than 6/6 [10/10] in the one eye. Satisfactory judgement of distance and wearing double protection when competing would be required for all riders with vision in only one eye.

Double vision is not compatible with the issuing of a competition licence.

The applicant, for any event except Trial, must have normal colour vision, in that they can distinguish the primary colours of red and green. If there is any doubt, a simple practical test is recommended under conditions similar to those of a race.

HEARING AND BALANCE

A licence can be issued to an applicant with impaired hearing but not to an applicant with a disturbance of balance.

A rider with impaired hearing must be accompanied at the riders briefing by a person with normal hearing who can communicate the information either by signing or in writing. The rider must wear a clearly visible tag that identifies him/her as hearing-impaired to the marshals and medical personnel in case of an accident/incident. The rider must also comply with the requirements of Article 09.4.4 of the FIM Medical Code.

DIABETES

In general, it is not considered advisable for diabetics to enter motorcycle events.

However, a well-controlled diabetic not subject to hypoglycaemic or hyperglycaemic attacks, and having no neuropathy nor any ophthalmoscopic evidence of vascular complications, may be passed as fit to compete.

CARDIO-VASCULAR SYSTEM

In general, a history of myocardial infarction or serious cardio-vascular disease would normally exclude a rider from speed events. Special attention should be paid to blood pressure and cardiac rhythm disorders. In such cases a certificate from a cardiologist including the results of any test the cardiologist considers necessary, must be submitted with the medical examination form.

With the exception of Trial any rider over the age of fifty years must have an exercise tolerance electrocardiogram performed, and the result must be favourable. In Trial, an exercise tolerance electrocardiogram is required for any rider over 50 years if there are known significant risk factors for or history of cardiac disease.

NEUROLOGICAL AND PSYCHIATRIC DISORDERS

In general, applicants with a serious neurological or psychiatric disorder will not be granted a licence.

FITS OR UNEXPLAINED ATTACKS OF LOSS OF CONSCIOUSNESS

A licence will not be issued if the applicant suffers from epilepsy, has suffered a single epileptic fit, or has suffered any episodes of unexplained sudden loss of consciousness.

For the Full FIM Medical Code- <http://www.fim-live.com/en/fim/the-commissions/medical/> BMST Management



MEDICAL HISTORY FORM

(to be completed by applicant)

Personal Data:

Name:	First name:	Date of birth	
Address:			
Sex	male	female	FMN:

No	Yes	Details
----	-----	---------

Loss of consciousness for any reason dizziness or headache

Eye problems (except glasses)

Asthma

Allergy to medicines or drugs

Diabetes

Heart problems

Blood pressure disorder

Stomach problems (ulcer, etc)

Uro-genital problems

Epilepsy or convulsions

Mental or nervous disorder

Problems with arms or legs
incl. muscle cramp or joint stiffness

Blood disorder with tendency to bleeding

Blood group

Operations

Do you take any medicine or drugs regularly?

- a. I have not been banned, on medical grounds, from taking part in any other sport.
- b. I do not take drugs and do not abuse alcohol.
- c. In case of an injury I give permission to the Medical Staff to release any relevant information to the clerk of the course, my relatives, my own doctor and the FMN.
- d. I declare that the information that I have given is the truth.
- e. I agree to the information on the Medical Examination Form being sent to the doctor of my FMN.

Date _____ Signature of applicant (or responsible Parent or Guardian if a minor)



MEDICAL EXAMINATION FORM
(To be completed by doctor)

APPENDIX B

Personal Data:

Name:		First name:		Date of birth	
Address:					
Sex:	male	female	FMN:		
Normal					Abnormal
	Details (if abnormal)				

<input type="checkbox"/>	Cardio-vascular system	<input type="checkbox"/>
<input type="checkbox"/>	*Exercercise tolerance ECG	<input type="checkbox"/>
<input type="checkbox"/>	*Echocardiography	<input type="checkbox"/>

<input type="checkbox"/>	Blood pressure	<input type="checkbox"/>
<input type="checkbox"/>	Pulse	<input type="checkbox"/>
<input type="checkbox"/>	Respiratory system	<input type="checkbox"/>

<input type="checkbox"/>	Nervous system	central	<input type="checkbox"/>
<input type="checkbox"/>		peripheral	<input type="checkbox"/>

<input type="checkbox"/>	Ear, nose and throat, right	<input type="checkbox"/>
<input type="checkbox"/>	in particular vestibulo-cochlear apparatus	left <input type="checkbox"/>

<input type="checkbox"/>	Locomotor-system	arm	right	<input type="checkbox"/>
<input type="checkbox"/>			left	<input type="checkbox"/>

<input type="checkbox"/>		leg	right	<input type="checkbox"/>
<input type="checkbox"/>			left	<input type="checkbox"/>

<input type="checkbox"/>		spine	<input type="checkbox"/>
<input type="checkbox"/>	Abdomen (hernia)		<input type="checkbox"/>

<input type="checkbox"/>	Urine	Albumen	<input type="checkbox"/>
<input type="checkbox"/>		Glucose	<input type="checkbox"/>

<input type="checkbox"/>	Eyes:	Distant vision	
<input type="checkbox"/>		without correction	right <input type="checkbox"/>
<input type="checkbox"/>			left <input type="checkbox"/>
<input type="checkbox"/>		with correction	right <input type="checkbox"/>
<input type="checkbox"/>			left <input type="checkbox"/>
<input type="checkbox"/>		color vision	<input type="checkbox"/>
<input type="checkbox"/>		visual field	<input type="checkbox"/>

*** In addition to the medical examination, an applicant for any license if 50 years of age or older must undergo and pass successfully an Exercise Treadmill Test (ETT) prior to the issuing of the license. The ETT must be completed and successfully passed every three years.**

I, the undersigned, certify that this person is medically fit to take part in motorcycle events

I, the undersigned, certify that this person is medically NOT FIT to take part in motorcycle events

I recommend that this person be examined by a member of the Medical Committee of the FMN, or doctor appointed by the FMN.

Date of examination

Signature and stamp of Doctor

APPENDIX 3 Consent Form

As a member of [FMN] and/or a participant in an event authorized or recognized by **FIM, CONU or FMN**, I hereby declare as follows:

I acknowledge that I am bound by, and confirm that I shall comply with, all of the provisions of FIM Anti-Doping Rules (as amended from time to time) and the *International Standards* issued by the World Anti-Doping Agency and published on its website.

I acknowledge the authority of FIM [and its member FMNs and/or National Anti-Doping Organizations] under the FIM Anti-Doping Rules to enforce, to manage results under, and to impose sanctions in accordance with, the FIM Anti-Doping Rules.

I also acknowledge and agree that any dispute arising out of a decision made pursuant to the FIM Anti-Doping Rules, after exhaustion of the process expressly provided for in the FIM Anti-Doping Rules, may be appealed exclusively as provided in Article 13 of the FIM Anti-Doping Rules to an appellate body for final and binding arbitration, which in the case of International-Level Riders is the Court of Arbitration for Sport (CAS).

I acknowledge and agree that the decisions of the arbitral appellate body referenced above shall be final and enforceable, and that I will not bring any claim, arbitration, lawsuit or litigation in any other court or tribunal.

I have read and understand the present declaration.

Date

Print Name (Last Name, First Name)

Date of Birth
(Day/Month/Year)

Signature (or, if a minor, signature of
legal guardian)



FIM WORLD RECORDS

APPLICATION FORM

To be completed and returned to the National Federation (FMN)
at least 30 days before the first day of the record attempt

The National Federation (FMN) concerned must apply for authorisation to the FIM Secretariat, at latest **1 month** before the date set for the attempt or the start of the event. By making this application, the FMN must ensure that the applicant has made the necessary arrangements for essential services and has obtained the required authorisations from local authorities, etc.

(PLEASE USE BLOCK CAPITALS)

Family Name		
First name		
Address (Rider)		
City		
Country		
Tel / Fax:		
E-mail:		
FIM Licence N°		
Name of Team or Sponsor		
Event name and date	Bonneville Motorcycle Speed Trials 27/AUG-01/SEP/2016	
Venue (City, Country)	BONNEVILLE SALT FLATS, UTAH USA	
Make/model of machine:		
Category, Group and Division		
Type, Class and number of cylinders		
Rider Number		
Type of record(s) to be attempted:	(1) Short Distance Flying Start Mile	
	(2) Short Distance Flying Start Kilo	
Date:	Signature:	

FMN:

Stamp

Signature:

IMPORTANT NOTICE

The application form is for advance registration purposes. The fact that a registration form has been stamped by the participants' National federation does not guarantee that the participants' machine has been automatically accepted. The participants' machine will be subject to a technical inspection by the appointed FIM Steward.

Article 018.30

If a record is still in the process of being ratified, any advertising concerning the results of the attempt must clearly state in sufficient legible characters « *SUBJECT TO FIM RATIFICATION* ».

These requirements must be respected and infringement will entail a fine of 10 times the ratification fee and/or other penalties stated in the FIM regulations.

AMA to FIM Conversion Chart.

Select your AMA frame class, and follow the applicable path, as you cross the FIM information write it down, add together and you have your FIM class

Key: FIM Classification = Category, Group, Division, Type, Class
 AMA Classification = Frame, Engine, Displacement

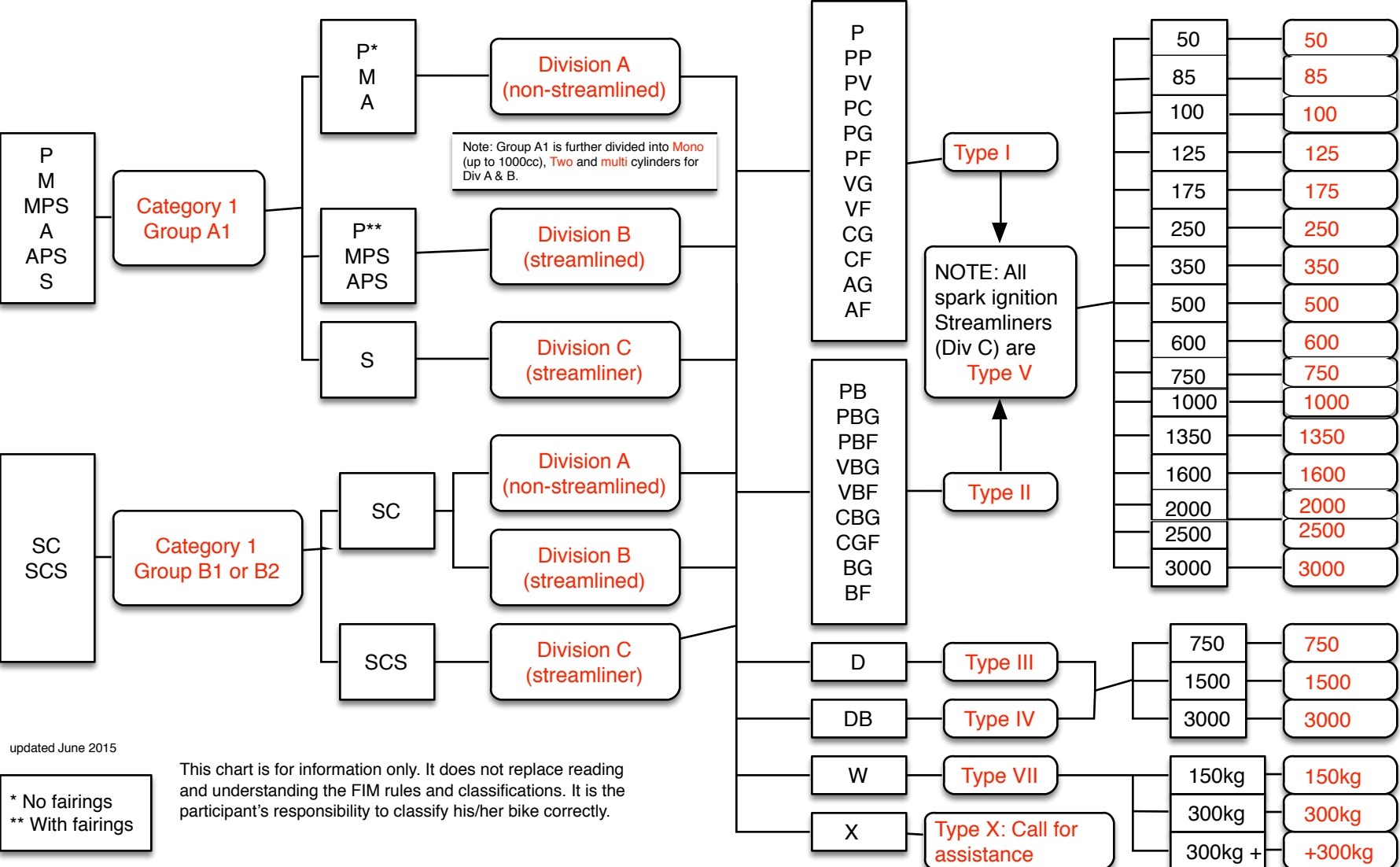
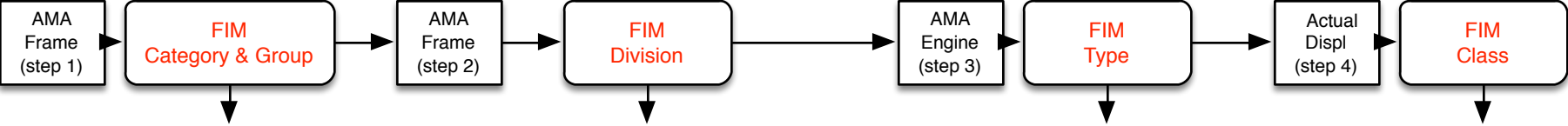

updated June 2015

* No fairings
 ** With fairings

This chart is for information only. It does not replace reading and understanding the FIM rules and classifications. It is the participant's responsibility to classify his/her bike correctly.